

HANDBOOK
OPERATING AND SERVICE
INSTRUCTIONS

MANSFIELD & GREEN
PNEUMATIC DEAD WEIGHT TESTER

MODEL HK – HIGH PRESSURE

FOR REPAIR AND RECALIBRATION
RETURN TO

8600 SOMERSET DR., LARGO, FL 33773

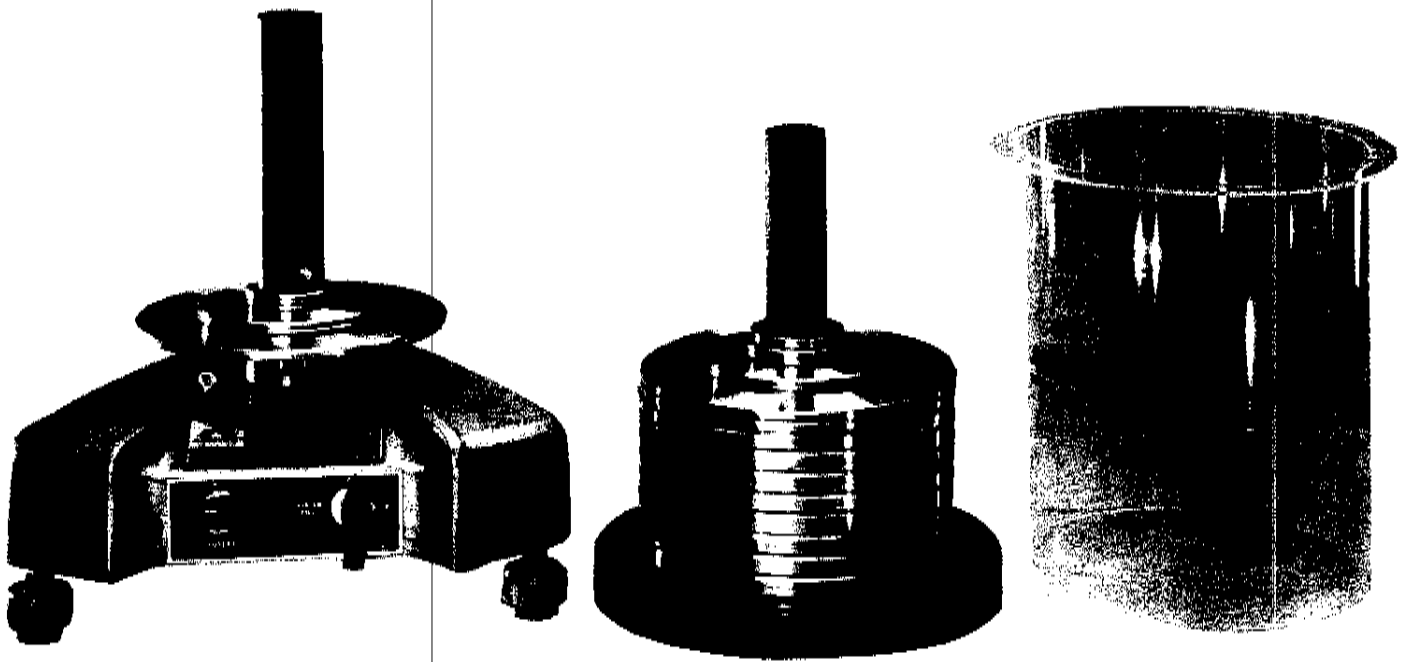

Model HK - High Pressure Tester

TABLE OF CONTENTS

- 1.0 DEAD WEIGHT TESTING, INTRODUCTION
 - 1.1 Correction Factors
 - 1.2 Recommended recertification Procedures

- 2.0 MODEL HK PNEUMATIC DEAD WEIGHT TESTER
 - 2.1 Model Description
 - 2.2 Assembly and Set Up Instructions
 - 2.3 Operating Instructions
 - 2.4 Maintenance and Trouble Shooting
 - 2.5 Illustrated Parts Breakdown

1.0 DEADWEIGHT TESTING, INTRODUCTION

The deadweight tester is one of the few instruments that can be used to generate pressure in terms of the fundamental units of force and area. Since only the fundamental units of force and area are involved for measurements, the deadweight tester need not be continuously referenced to another pressure instrument for its calibration accuracy. Deadweight testers are thus considered primary laboratory pressure standards.

Construction of deadweight testers varies as to the methods of loading weights, rotating or oscillating the piston to reduce friction, and the design of the piston and cylinder. The Mansfield and Green Pneumatic Dead Weight Testers employ a unique method of operation. Clean, dry air or nitrogen is supplied from a built in flow regulator to an equalizing annulus and from there under the ball to the output port. The ball, with weight hanger and weights, floats on a film of air.

1.1 CORRECTION FACTORS

It is obvious that error in pressure determinations can result from any uncertainty of the mass of the loading weights and from the measurement of the effective area of the ball and nozzle. Other sources of error may not be so easily recognized. Such sources include the air buoyancy of the weights, gravity, thermal expansion and elastic deformation of the ball and nozzle, and the air heads involved. All of these corrections with the exception of local gravity (except when specified), thermal expansion, and air head have been corrected on the testers as shipped by Mansfield & Green.

The following technique is suggested to compute corrected tester output pressure readings:

1.1.1 GRAVITY

The value of local gravity can differ by more than 0.2% at different locations in the United States. As pressure is defined as "force per unit area", the mass values must be converted to force values. To accomplish this, the acceleration of gravity must be used. The acceleration of local gravity may be determined by having a gravitational survey made of the local area with a gravimeter or by contacting the National Oceanic and Atmospheric Administration, U.S. Department of Commerce. Once the local value of gravity is known, the pressure may be corrected using the following equation.

$$P_G = \frac{G}{G_W} \times P_N$$

Where:

P_G — tester output pressure corrected only for gravity

G — local gravity

G_W — gravity value for which the tester is calibrated

P_N — pressure value of weights applied

1.1.2 TEMPERATURE

If the coefficient of expansion of the ball and nozzle is positive the effective area will increase with increasing temperature resulting in a corresponding decrease in pressure. Corrections can be made using the following formula.

$$P_T = \frac{P_G}{1 + 1.65 \times 10^{-5} (T - 23^\circ \text{C})}$$

Where

P_T = Tester output pressure corrected for gravity and temperature

T = Ambient temperature ($^\circ\text{C}$)

1.1.3 AIR HEAD

When pressurized, a correction is required only when the gage height or reference plane of the unit being calibrated is either higher or lower than that of the pneumatic tester. The reference plane of the pneumatic testers is at the top of the nozzle. Heights above the reference plane are negative, while heights below the reference plane are positive. Corrections can be made using the following formula.

$$P_A = P_T (1 + H \times 2.84 \times 10^{-6})$$

Where

H = Air head (inches)

P_T = Tester output pressure corrected for gravity and temperature

P_A = Tester output pressure corrected for gravity, temperature, air head

1.2 RECOMMENDED RECERTIFICATION PROCEDURES

1.2.1 INTRODUCTION

All deadweight pressure testers produced by AMETEK MANSFIELD & GREEN DIVISION are tested and certified in the AMETEK MANSFIELD & GREEN DIVISION laboratory for accuracy of pressure produced, with results traceable to the National Bureau of Standards.

This accuracy can degrade with wear resulting from continued use and/or accidental damage. AMETEK MANSFIELD & GREEN DIVISION recommends all instruments be periodically retested for accuracy and pressure produced. Testers returned to AMETEK MANSFIELD & GREEN DIVISION will be "tested and (re)certified for accuracy traceable to NBS" or "tested and (re)certified with data furnished traceable to NBS" if tester is in operable condition.

1.2.2 FREQUENCY OF RECERTIFICATION

The recommended frequency of output pressure recertification is a direct function of the frequency and type of use to which the tester is applied. As a general rule, AMETEK MANSFIELD & GREEN DIVISION pneumatic testers should be tested and recertified every 12 months. Testers used frequently should be tested and certified at more frequent intervals. Master units used infrequently will need to be tested and certified less frequently.

1.2.3 MATERIAL NECESSARY FOR RECERTIFICATION

The entire tester and weight set must be returned to AMETEK - Mansfield & Green Division for recertification.

1.2.4 PACKAGING INSTRUCTION

All parts returned to AMETEK - Mansfield & Green Division must be securely packaged to preclude damage in shipping.

PNEUMATIC TESTERS

Testers should be returned in their normal cases and the cases packaged to prevent damage in shipping. Weights should be individually packaged in such a manner to preclude shipping damage.

2.0 MODEL HK PNEUMATIC DEADWEIGHT TESTER

2.1 MODEL DESCRIPTION

The model HK tester is a self-regulating, primary pressure standard with high pressure capacity up to 1500 PSI. This instrument operates on the deadweight principle using only fundamental units of force and area. The output pressure is equal to the weight force divided by the effective area of the ball.

Accuracy of all models of this instrument is +/- .025 PSI or +/- .25% of the indicated pressure reading, whichever is greater. All model HK testers include the tester, weights and weight carrier, a weight storage container and a carrying case.

TABLE 1 — MODEL HK PNEUMATIC DEAD WEIGHT TESTERS

MINIMUM MODEL	RANGE	INCREMENT
HK-30	10-300 PSIG	1 PSI
HK-500	10-500 PSIG	1 PSI
HK-700	10-700 PSIG	1 PSI
HK-1000	10-1000 PSIG	1 PSI
HK-1500	100-1500 PSIG	1 PSI
HK-70M	.5-70 KG/CM2	.1 KG/CM2
HI-70B	.5-70 BAR	.1 BAR
HK-7000N	50-7000 KPA	10 KPA

TABLE 2 — MODEL HK WEIGHT SETS

MODEL	WEIGHT CARRIER AND BALL	WEIGHTS FURNISHED PER PRESSURE INCREMENT								
		1 PSI K-2047-4	2 PSI K2047-16	5 PSI K-2041	10 PSI K-2019	20 PSI K-2019-4	50 PSI K-2020	90 PSI K-2032	100 PSI K-2021	200 PSI K-2077
K-1550										
HK-300	10 PSIG	1	2	1	1	2	1	1	1	
HK-500	10 PSIG	1	2	1	1	2	1	1	3	
HK-700	10 PSIG	1	2	1	1	2	1	1	5	
HK-1000	10 PSIG	1	2	1	1	2	1	1	8	
HK-1500	10 PSIG*	1	2	1	1	2	1	1	1	6
K-1550-2		.1KG/CM2 K-2047-8	.2KG/CM2 K-2023-8	.5KG/CM2 K-2023-6	1 KG/CM2 K2036-10	2KG/CM2 K2036-20	5KG/CM2 K-2032-3	9.5KG/CM2 K2037-22	10KG/CM2 K2037-13	
HK-70M	.5KG/CM2	1	2	1	1	2	1	1	5	
K-1550-3		.1 BAR K-2047-9	.2 BAR K-2023-8	.5 BAR K-2023-4	1 BAR K2036-12	2 BAR K2036-19	5 BAR K-2032-6	9.5 BAR K2037-24	10 BAR K-2037-19	
HK-70B	.5 BAR	1	2	1	1	2	1	1	5	
K-1550-3		10 KPA K-2047-9	20 KPA K-2023-8	50 KPA K-2023-4	100 KPA K2036-12	200 KPA K2036-19	500 KPA K-2032-6	950 KPA K2037-24	1000 KPA K2037-19	
HK-7000N	50 KPA	1	2	1	1	2	1	1	5	

* — MINIMUM OPERATING PRESSURE OF THIS MODEL IS 100 PSIG

NOTE: The Serial Number of the unit must be specified on the order when ordering replacement and/or additional weights, weight carriers and weight sets.

2.2 ASSEMBLY AND SETUP INSTRUCTIONS

2.2.1 BALL AND NOZZLE

Check the ceramic ball and nozzle for cleanliness. Remove the nozzle by loosening the Nozzle Nut (K-1552) and removing the Ball Retainer (K-1401). The Ball (K-1408) may be carefully set aside and the Nozzle (K-1406) is withdrawn by pulling vertically with a slight twisting motion. It is recommended that the ball and nozzle be frequently cleaned with a residue free solvent such as Freon TF.

CAUTION

The nozzle is marked with serial numbers on both ends. It must be reassembled with the end marked "UP" on the top side.

Replace the ball in the end of the nozzle and tighten the nozzle nut and ball retainer. If the parts do not reassemble smoothly, take them apart and re-examine for misassembly. **Do not force any parts into place or the tester may be permanently damaged.**

2.2.2 LEVELING

It is important that the tester be used on a vibration-free surface and the test area free of excessive air currents. Adjust the leveling feet to bring the tester into level and lock the locking nuts. A bull's eye level is mounted on top of the base casting and has been carefully adjusted at the factory.

CAUTION

DO NOT TAMPER WITH THE SETTING OF THIS LEVEL

2.2.3 CONNECTION

Input and output connections to the tester are ¼" OD tubing, 7/16-20, 37° AN male. Flexible lines are recommended for both input and output connections. Tubing must be rated for use at 1500 PSI. (2250 PSI For HK-1500). Recommended input pressure is 1300 PSI (2000 PSI for model HK-1500). Compressed gas must be free of all oil, water and contaminants.

CAUTION

DO NOT ALLOW INPUT PRESSURE TO EXCEED 1500 PSI! (2250 PSI for model HK-1500 only). HOLD INLET AND OUTLET FITTINGS WITH A WRENCH TO KEEP THEM FROM TURNING WHEN MAKING OR BREAKING CONNECTIONS WITH THE TESTER!

Connect a ¼" AN fitting to the output port tester. It is important that this line is free of leaks and the down stream volume to be 6 cubic inches or more. Any output leaks will result in erroneous calibration pressure (at the gauge, transducer, etc).

2.2.4 CONTAMINATION

Under no circumstances should any mercury or corrosive fluids be permitted to get into the tester. When the tester is used in connection with an instrument or pressure system that contains a liquid, a suitable safeguard such as a trap or float type manometer check valve should be installed in the tester output line to prevent fouling of tester components.

2.3 OPERATING INSTRUCTIONS

CAUTION

The model HK-1500 has different internal construction than other HK models. Using the model HK-1500 below 100 psi will produce inaccurate output pressures. Do not attempt to produce 1500 psi output from testers not specifically built as HK-1500, as this could result in internal damage to tester and inaccurate output pressures.

The Model HK Tester incorporated an exclusive system fill capability to reduce the time necessary to initiate operation, especially when large volumes are connected to the tester output. Operation is accomplished by the following steps.

- 2.3.1 Set up the tester as described in Section 2.2.
- 2.3.2 Place both the "Input" and "Output" valves in the "on" position.
- 2.3.3 Slip the weight carrier over the nozzle column. Add weights for the desired output pressure.

- 2.3.4 Rotate the "Input" valve to the "System Fill" position.
- 2.3.5 When the weight stack visibly rises and/or the loud hissing of air can be heard blowing past the ball, return the input valve to the "off" position for a moment to equalize the internal pressures, then turn the valve to the "on" position.

CAUTION

Turning the valve rapidly from "System Fill" to "ON" without pausing at "OFF" may result in damage to the regulator. Allowing the input valve to remain in the "System fill" position when testing will result in inaccurate output pressures.

- 2.3.6 The tester, being self regulated, will come to a set pressure by itself. Once the valve is placed in the "ON" position, the weights should be hand-steadied to prevent excessive oscillations. This is done by placing a hand under the weight stack and lifting gently. Remove hand from weights before testing.

Use care in handling tester weights. Do not allow them to drop sharply on the weight carrier shoulder or try to load several weights at the same time. The weight carrier stop, at the base of the column, has been carefully adjusted so that in shutting off the air supply to the tester the weight carrier is arrested before the ceramic ball can be driven into the socket of the nozzle body.

It is not necessary to spin the weights of this tester to overcome friction. However, to aid the self cleaning feature of the tester (wherein the air flow keeps the ball and nozzle area free of dust, etc.), and as an indication that no part of the weight carrier is rubbing against the column (which will be indicated by a rapid decrease in rotation), we suggest the weights be rotated very slowly.

CAUTION

BALL, WEIGHT CARRIER AND WEIGHTS ARE MARRIED TO THE CALIBRATOR AT MANUFACTURE. ACCURACY WILL BE AFFECTED IF WEIGHT CARRIERS, BALLS OR WEIGHTS ARE INTERCHANGED WITH OTHER TESTERS OF THIS TYPE.

3.4 MAINTENANCE AND TROUBLE SHOOTING

3.4.1 CLEANING AND OUTPUT RESTRICTION

Remove the nozzle nut, nozzle, ball and ball retainer. Connect air or nitrogen supply to tester output, **set supply pressure at 50 PSI**. Put input valve in "OFF" position. Carefully put Output valve in the "ON" position.

CAUTION

A high pressure stream of gas will exit through the restriction. Do not place eyes or any part of the body in this stream or injury can result.

3.4.2 LEAKS IN OUTPUT CONNECTIONS

Load the tester so as to apply a pressure to the instrument being calibrated. Put the Output Valve in the "OFF" position. If the pressure indicated by the instrument being tested is maintained, it is safe to assume that there are no leaks between the tester and the instrument.

3.4.3 LEAKS INTERNAL WITHIN TESTER

Do not attempt to repair internal leaks. Return the tester to AMETEK/MANSFIELD & GREEN for repair or warranty is void.

3.4.4 CORRECTING FOR POOR ROTATION OF WEIGHTS

1. Check cleanliness of ball and nozzle as described in Section 2.2.1.
2. Make sure tester is leveled as described in Section 2.2.2.
3. Isolate tester from environmental vibrations or relocate tester.
4. Check for adequate air/nitrogen supply.

3.4.5 SETTING OF WEIGHT CARRIER STOP

1. With weight carrier in place on the ball and no pressure applied to tester, the ball must have slight verticle movement.
2. With the weight carrier in place on the ball and input pressure applied, a visible clearance must exist between the base of the weight carrier and the top of the weight carrier stop.
3. Load the weights on the weight carrier for 1000 PSI. Place the Output valve in the "Off" position and the Input valve in the "On" position. The weight stack should rise to the test position in 4 to 6 minutes.
4. If the rise time is below 4 minutes, loosen the set screw and lower the Weight Carrier Stop ¼ turn counterclockwise. Tighten set screw and retest as described in steps 1-3.

3.4.6 REPLACING THE NOZZLE O RING

Remove the nozzle nut, retainer, ball and nozzle, and nozzle O ring (10-90006). The replacement O ring should be wiped clean with a lint free cloth and placed within the groove in the nozzle body. **Do not lubricate the O ring with any oil or grease**. Clean the ball and nozzle as described in Section 2.2.1 and reassemble.

3.5 ILLUSTRATED PARTS BREAKDOWN

The Model HK Tester is carefully tested for both internal leakage and accuracy of output pressure prior to shipping from Mansfield & Green. No internal adjustments and/or alterations may be made or the Warranty is voided. If the tester is malfunctioning and the external adjustments described in Section 2.4 do not cure the problem it must be returned to Mansfield and Green for repair.

The Illustrated Parts Breakdown for the Type HK Tester is shown on Figure 3.

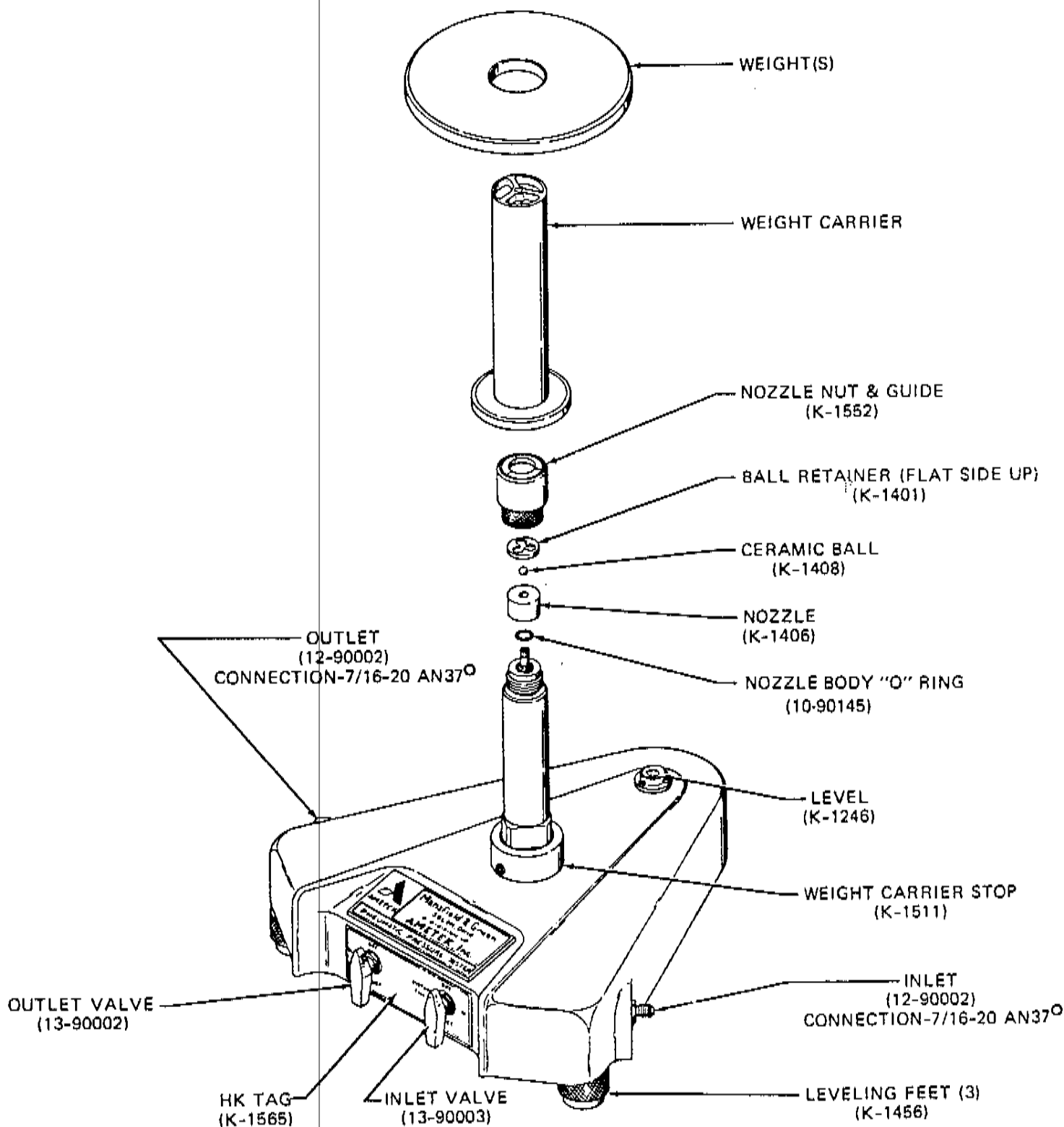

AMETEK

CODE IDENT NO. 92456	REVISIONS	DATE	APPROVED

PNEUMATIC PRESSURE TESTER
ILLUSTRATED PARTS BREAKDOWN
FIGURE III