

# LF Plus Series

## Digital Testing Machine

The LF Plus Series digital testing machine is an easy to use solution for force measurement and material testing applications up to 1 kN (225 lbf) capacities. The machine uses interchangeable XLC Series loadcells as the measurement device. Tension and compression testing with cycling to load and extension limits are standard features. The machine can be equipped with a variety of accessories including: grips, fixtures, compression frames and extensometers.

The LF Plus features an innovative design that maximises working space and simplifies operation and maintenance. The large work surface accommodates large specimens and can be specified with optional work surfaces for specialised fixtures or applications.

The LF Plus Series displays load and extension information on a highly legible LCD console with integral membrane keypad. The machine's intuitive firmware displays prompts and menus which guide an authorised user through machine operations. Users can choose from a range of display languages.

The machine performance can be maximised when combined with our NEXYGEN™ FM application software. This WINDOWS® based software is equally easy-to-use and allows detailed force measurement and material testing data to be stored and displayed in graphical and tabular formats. The software also lets you manipulate data to produce detailed analytical reports, plus the ability to integrate with popular WINDOWS® software packages including EXCEL®, ACCESS®, WORD®, POWERPOINT® and OUTLOOK®.

### Features

- Large Working Area
  - Flexible Work Surface Configurations
  - 175 mm (6.9 in) Throat for Large Specimens
- Flexible and Accurate Load Measurements
  - XLC Series Loadcells
- Intuitive Operator Interface
  - Menu Driven with Intelligent Prompts
  - Membrane Keypad with Tactile Feedback
  - Highly Legible, backlit LCD Display
- Integral Cabling
- Motor Servo Control System
- Flash Memory Upgradeable
- Full PC Integration with NEXYGEN™ FM Software
- Load Rate Control
- Constant Load Holding



### Specifications

Capacity:	1 kN (225 lbf)
Crosshead Speed:	0.05 to 1270mm/min
(at full load)	0.002 to 50 in/min
Speed Accuracy:	<0.2%
Loadcell Accuracy:	±0.5% of reading
Extension Resolution:	Better than <1.3 microns (0.0013 mm)
Standard Travel:	500mm (20 in)
Data Acquisition Rate:	80 kHz
Data Sampling Rate:	1000 Hz
Display:	40 character x 4 line backlit LCD
Inputs:	RS232 Serial Data
	Digital and analogue Extensometer
Outputs:	RS232 Serial Data
	Analogue 10Vdc max (optional)
Standard Languages:	English, Danish, Italian, French, German
Power:	115/230V ac 50-60Hz
Measuring System:	Exceeds the requirements of BS EN ISO 7500:1999.
	Class 0.5 or Class1, ASTM E4, DIN 51221
Safety Features:	Emergency Stop, Frame Overload Protection,
	Loadcell Overload Protection, Operator Password.
Weight:	46 Kg (101 lb)
Warranty:	2 years

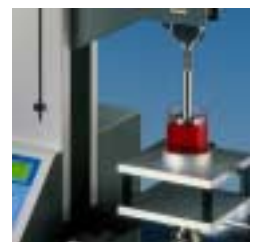

**SPECIFICATION**  
SS-MT-6124-0801  
August 2001

[www.ametek.com](http://www.ametek.com)  
[www.chatillon.com](http://www.chatillon.com)  
[www.lloyd-instruments.co.uk](http://www.lloyd-instruments.co.uk)

AMETEK and CHATILLON are registered trademarks of AMETEK, Inc.  
LLOYD INSTRUMENTS, NEXYGEN and ONDIO are trademarks of AMETEK, Inc.

Copyright 2001, by AMETEK, Inc.

**LLOYD**  
INSTRUMENTS™  
A trademark of AMETEK Inc.

## Ordering Information

Order No. Description

01/LFL **BASE Model Number - 1st thru 6th Characters**  
LLOYD LF PLUS Testing Machine

**Travel Length - 7th Character**

S Standard, 500 mm (20 in)  
E Extended, 750 mm (30 in)  
P Pogo  
X Extended Pogo

Available Soon

**Work Surface - 8th Character**

A Standard Base  
B Expanded Work Table - M6 Threads  
C Expanded Work Table - 10-32 UNF Threads  
D T-Slot Table  
E Drip Tray

**Mains Power - 9th thru 11th Characters**

/US 120V ac Mains Power  
/UK 230V ac Mains Power  
/EU 220V ac Mains Power

01/LFL S C /US **Sample Order Number - (01/LFLSC/US)**

LLOYD LF Plus Testing Machine, Standard 500 mm travel with expanded work table with 10-32 UNF threads and 120V ac power.

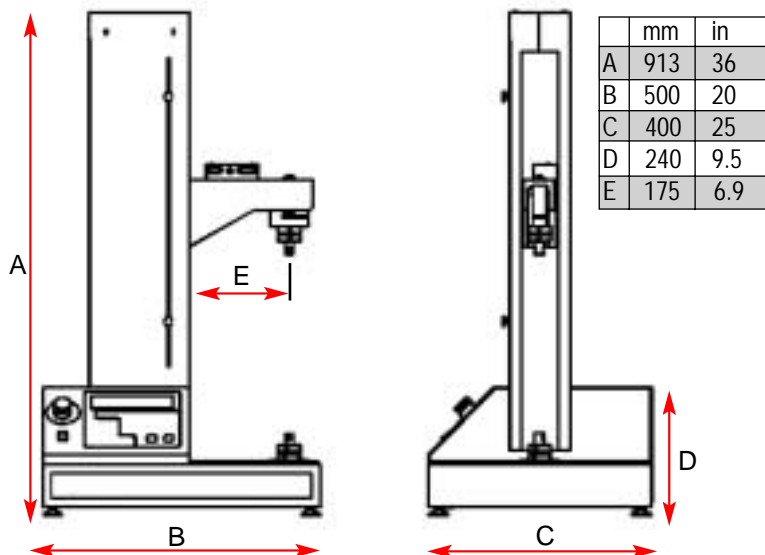

## Accessories

Item Part No.

**Loadcells:**

5 N (1 lbf)	01/2946
10 N (2 lbf)	01/2360
20 N (4 lbf)	01/2950
50 N (11 lbf)	01/2361
100 N (22 lbf)	01/2480
250 N (55 lbf)	01/2992
500 N (110 lbf)	01/2362
1000 N (225 lbf)	01/2419

**Extensometers:**

Comprehensive range of contacting and non contacting extensometers are available. For further information see specification sheet number :  
SS-MT-6603

**Application Software:**

NEXYGEN™ FM Single license	40/0738
NEXYGEN™ FM Five Seat license	40/0738/5
NEXYGEN™ FM Ten Seat license	40/0738/10
NEXYGEN™ MT	40/0658
NEXYGEN™ MT (upgrade)	40/0658/NR

**Grips & Fixtures:**

All grips up to a capacity of 10 kN (2200 lbf) can be used. Specification sheet numbers for the range are indicated below:

Wire, Yarn & Thread Grips	SS-MT-6422
Food Texture Analysis Grips	SS-MT-6420
Wedge Grips	SS-MT-6409
Vice Grips	SS-MT-6408
Friction, Peel, Paper & Adhesive Grips	SS-MT-6407
Self Tightening Grips	SS-MT-6406
Pneumatic Grips	SS-MT-6405
Flexural Grips	SS-MT-6403
Compression Platens	SS-MT-6402
Chuck & Colett	SS-MT-6401

**Work Tables:**

Expanded Work Table (350 mm x 400 mm) with M6 tapped holes for custom fixings:	SPK/LFM/0007
Expanded Work Table (350 mm x 400 mm) with 10 - 32 tapped holes for custom fixings:	SPK/LFM/0008
Aluminium T-Slot Table (180 mm x 340 mm) for adjustable fixings:	SPK/LFM/0009
Drip Tray for food testing:	SPK/LFM/0010

**AMETEK**  
TEST AND CALIBRATION INSTRUMENTS

WINDOWS, EXCEL, ACCESS AND POWERPOINT are registered trademarks of Microsoft Corporation

**UK**  
Lloyd Instruments Ltd  
Forum House  
12 Barnes Wallis Road  
Segensworth East, Fareham  
Hampshire, PO15 5TT  
UK  
Tel: +44 (0)1489 486 399  
Fax: +44 (0)1489 885 118

**America**  
AMETEK TCI Division  
8600 Somerset Drive  
Largo  
Florida 33773  
USA  
Tel: +1 (727) 536 7831  
Fax: +1(727) 539 6882

**Far East**  
Lloyd Instruments  
Far East Representative Office  
No7 Sherwood Place  
Alexander Heights  
6064 Perth  
WESTERN AUSTRALIA  
Tel: +61 8 9343 5725  
Fax: +61 8 9343 5723

**France**  
Lloyd Instruments SA  
3 avenue des Coudriers  
Zone d'activite de l'observatoire  
78180 Montigny-Le-Bretonneux  
FRANCE  
Tel: +33 (1) 30 57 47 74  
Fax: +33 (1) 30 57 50 33

**Germany**  
AMETEK Precision Instruments  
Europe GmbH  
Rudolf-Diesel-Straße 16  
D-40670 Meerbusch  
GERMANY  
Tel: +49 (0)2159 9136-70  
Fax: +49 (0)2159 9136-80

email: general@lloyd-instruments.co.uk  
www.lloyd-instruments.co.uk

Information within this document is subject to change without notice.

ISO 9001  
Manufacturer