

# LS1

## 1 kN / 225 lbf Advanced Materials Testing System



### Features

#### High Mechanical Stiffness

Modern linear guide technology, pre-loaded ball screws and advanced software compensation systems ensure the highest precision for displacement measurement

#### Wide Speed Range

0.01-2032 mm/min - High precision and improved productivity

#### Exceptional Accuracy

Load accuracy of +/- 0.5% down to 1% of load cell value provides high dynamic range, thereby reducing the number of load cells required to cover the full force range

#### Flexible Controls

Scalable from stand alone operation via a hand held controller or a control console, alternatively utilising our highly acclaimed NEXYGENPlus software

#### Control Interface

PC interface is via USB allowing standard laptops to be used with no special PC interface cards required

#### Advanced Test Setup with NEXYGENPlus

The Windows® 7 compatible NEXYGENPlus software features an improved and intuitive User Configurable Test functionality complementing the comprehensive test standards library available

The LS1 is a 1 kN / 225 lbf high precision materials testing machine that combined with our extensive range of grips, fixtures, extensometers and software creates a powerful materials testing system. The system is equally suited to quality control, educational and R&D environments within a wide range of applications and test types, including medical devices, plastics, packaging, textiles, rubber and electronics to name a few.

- Meets or exceeds national and international material test standards
- Intuitive operation and low maintenance
- Small tabletop footprint with a large and flexible work space
- Suitable for a wide range of test applications
- Plug 'n' Play, automatic identification of XLC series load cells
- NEXYGENPlus provides seamless data transfer to Microsoft Office®, LIMS and other data management systems

### Test Types

Tensile Testing • Compression Testing • Flexural Testing • Friction • Insertion/Extraction • Peeling • Tearing • Creep/Relaxation

# NEXYGEN<sup>Plus</sup> Materials Testing and Data Analysis Software

## NEXYGEN<sup>TM</sup> PLUS

NEXYGEN<sup>Plus</sup> materials testing software is the hub of the Lloyd Instruments materials testing system. This extraordinarily easy to use and flexible software, allows the operator to control and monitor all aspects of the system from a single front end, ensuring fast, reliable and powerful testing and data analysis for tensile, compression, peel, creep, relaxation and flexural test applications.

### Features

- Large built-in library of test methods meeting international test standards
- Intuitive User Configurable Test facility
- Video and still capture for visual analysis
- User access settings and data traceability enabling compliance with FDA 21 CFR Part 11
- Built in SPC functionality for continuous monitoring of process parameters such as Cp and Cpk
- Microsoft Office® integration for seamless transfer of data to familiar Windows® packages, Windows® 7 compatible
- Versatile data export facility to LIMS, SPC or data management systems
- Test automation and batch testing

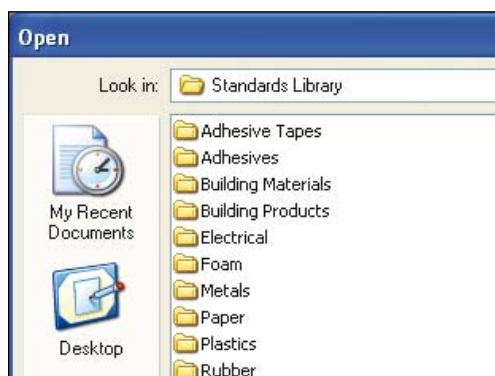

Standards Library

## Test Creation

Getting started with NEXYGEN<sup>Plus</sup> is simple, thanks to:

- An extensive built-in library of test methods covering ASTM, DIN, EN, ISO and other standards
- Test wizards for tension, compression, tearing, peeling, friction and flexural tests
- The User Configurable Test facility, ideal for product and component testing

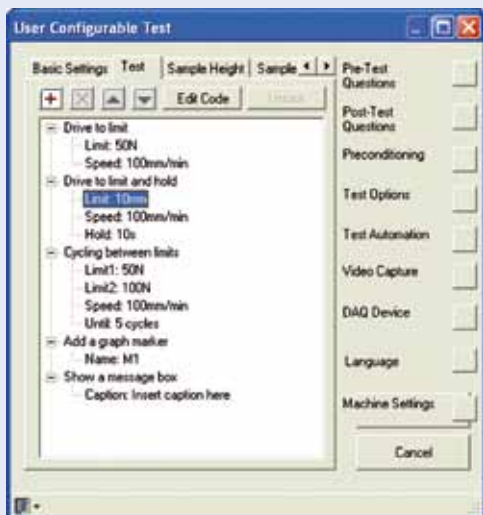

User Configurable Test

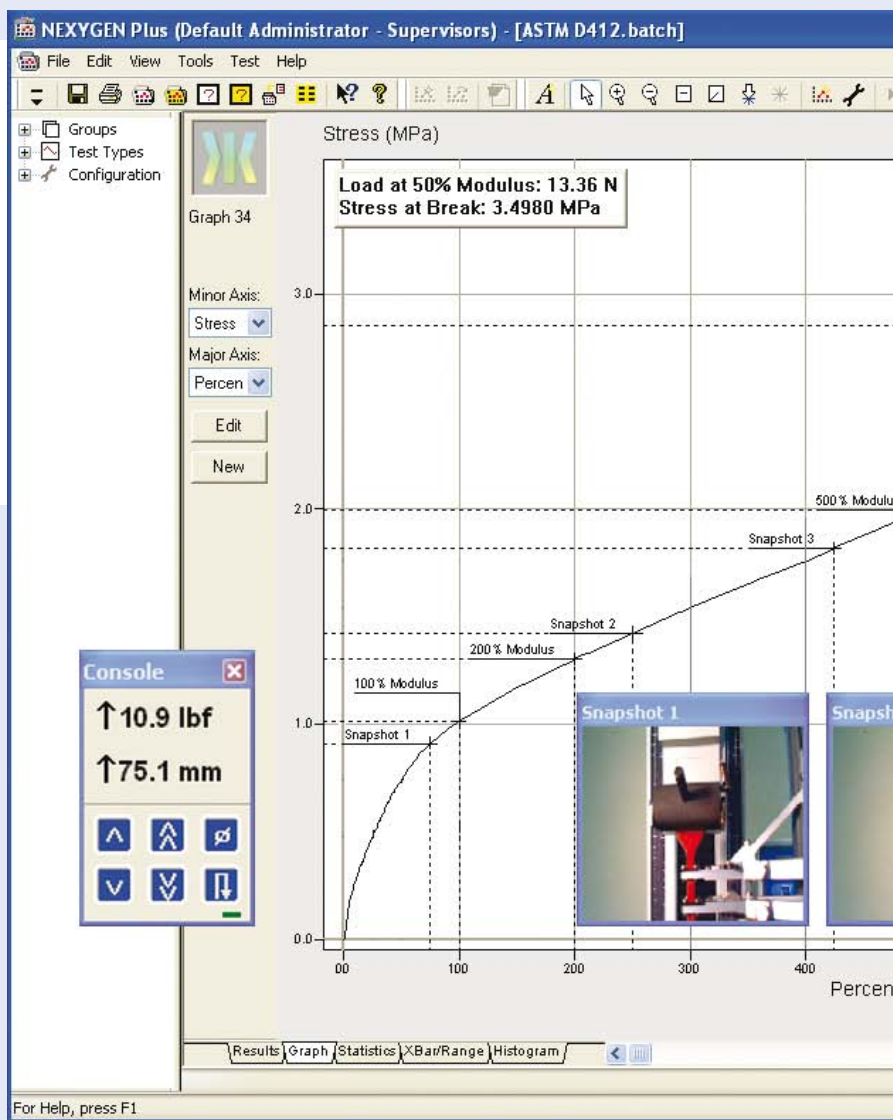

## New User Configurable Test

The new User Configurable Test enables users to quickly build advanced multi-stage test routines using simple built-in commands.



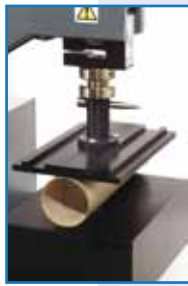

## Grips and Fixtures

Choose from a wide range of standard grips and fixtures as well as custom designed versions.

- Wedge action grips for rigid samples
- Pneumatic action grips for faster sample clamping
- Vice action grips for film and semi rigid materials
- Compression platens available in many sizes
- 3 and 4 point bending jigs
- Self tightening grips to reduce operator fatigue
- Bollard grips for wire and rope testing

## Multi-lingual

NEXYGEN*Plus* software is available in the following languages:

English • Spanish • French • German • Italian • Danish • Turkish  
Chinese • Russian

## Video and Still Picture Capture

Whether for advanced sample failure analysis or presentation of test results, video and stills capture is a feature unique to NEXYGEN*Plus*. Video and/or still pictures are synchronised with the stress/strain data and can be replayed or shown at specific points during the test in the graphical display. To utilise these powerful features simply connect your web cam or analogue video camera to your PC.

Still Picture Capture

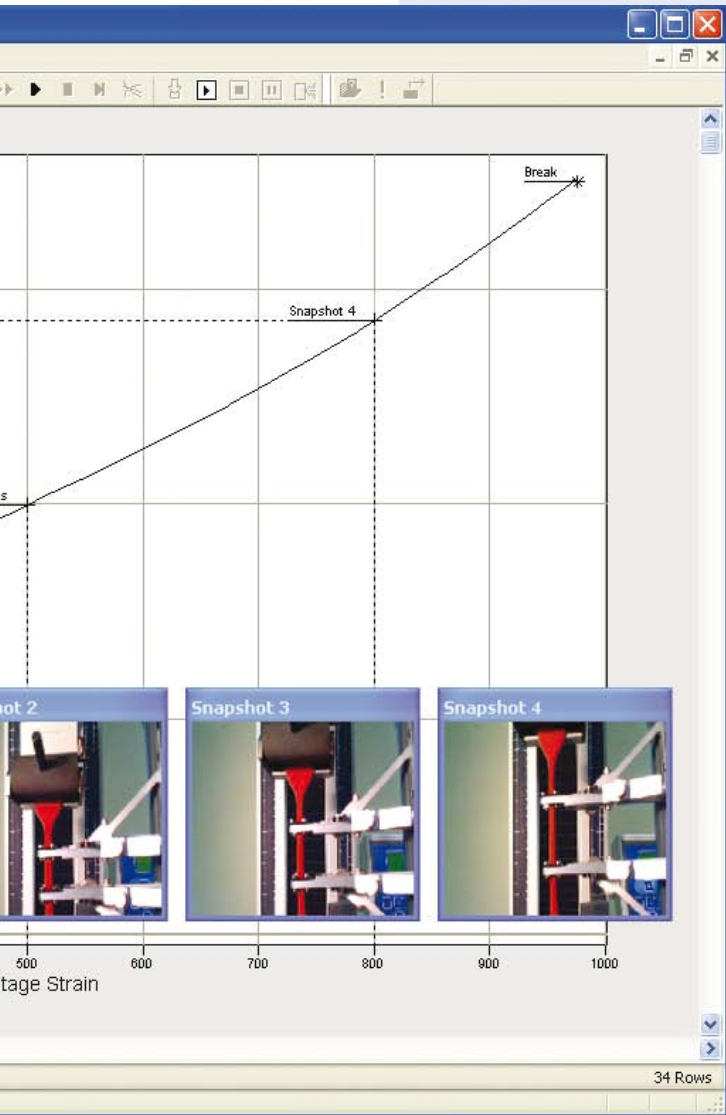

## Test Automation and Customisation

To facilitate the increasing use of automation in manufacturing, NEXYGEN*Plus* has been developed with powerful utilities for systems integration. Typical integration projects include:

- Automated sample handling
- In-line testing
- Monitoring of parameters from other sensors, e.g. thermocouples and strain gauges
- Customisation of the user interface and other functionality via the integrated Microsoft VBA module



## Technical Specification

Force Capacity	1000 N (225 lbf)
Max. Crosshead Travel, Standard Travel ( <i>Between the Eye Ends</i> )	500 mm (19.7 in)
Max. Crosshead Travel, Extended Travel ( <i>Between the Eye Ends</i> )	800 mm (31.5 in)
Crosshead Speed Range	0.01-2032 mm/min (0.0004-80 in/min)
Maximum Return Speed	2032 mm/min (80 in/min)
Speed Accuracy ( <i>Unloaded</i> )	+/-0.2% of reading from 2% to 100% of max. speed
Min. Load Resolution ( <i>Load Cell Specific</i> )	0.0001N (2.2x10 <sup>-5</sup> lbf)
Load Cell Accuracy	+/-0.5% from 1% to 100% of load cell value
Extension Resolution	<0.1 microns
Data Sampling Rate	8kHz
Extensometer Inputs	Optional
Load Measuring System	EN ISO 7500:2004, Class 0.5 ASTM E4
Relative Humidity	20% to 85%
Operating Temperature	+5 to 35°C (41 to 95°F)
Storage Temperature	-17 to 54°C (0 to 130°F)
Supply Voltage (+/- 10%)	115VAC/230VAC, 50-60Hz
Max. Power Requirement	2.5A@115VAC/ 1.6A@230VAC

All systems conform to relevant EU standards and are CE marked.  
On site verification as per ASTM E4 and ISO 7500-1 recommended.

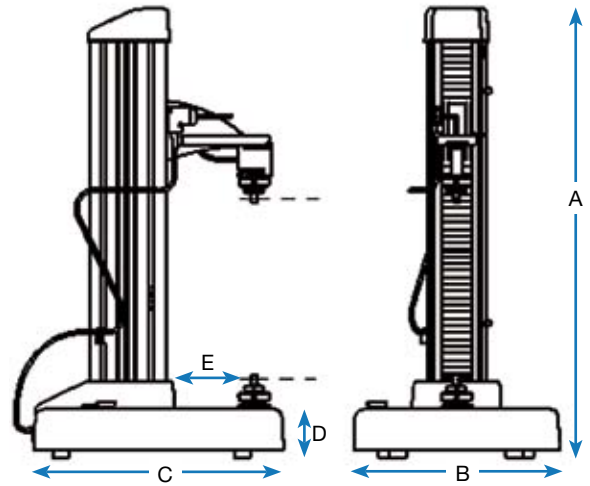

## Dimensions & Weight

A	Height (standard travel)	1001 mm (39.4 in)
A	Height (extended travel)	1301 mm (51.2 in)
B	Width (excluding console)	460 mm (18.1 in)
C	Depth	557 mm (21.9 in)
D	Base Height	108 mm (4.3 in)
E	Throat Depth	180 mm (7.1 in)
	Weight (standard travel)	52 kg (115 lb)
	Weight (extended travel)	62 kg (137 lb)

## Ordering Information

Order number	Description
LS1	LS1
	<b>Model</b>
S	Standard Travel
E	Extended Travel
P	Standard Travel POGO Design*
X	Extended Travel POGO Design*
	<b>Operation</b>
H	Hand Held Remote
C	Main Console
	<b>Power</b>
115V	US Power Cord
230V	UK and Euro Power Cord
230V - CNAU	China and Australian Power Cord
	<b>Order number sample</b>
LS1 E C 230V	LS1, Extended Travel, Main Console, UK and Euro Power Cord

\*Our unique POGO system allows testing of very large samples with the added benefit of optional elevated and low temperature testing capability.

**AMETEK**<sup>®</sup>  
TEST & CALIBRATION INSTRUMENTS



ISO 9001 Manufacturer

[www.lloyd-instruments.com](http://www.lloyd-instruments.com)

For more info or to place an order for LS 1 in Canada please visit:  
<http://www.dmm.ca/LS1-testing-machine.html>

